

# PHOS 20 LED PROJECTOR



## SPECIFICATIONS

item:	PHOS 20
body:	aluminium
available colours:	silver / black / white
weight:	2.8 kg
on / off switch:	on the backside of the device foot
environmental conditions:	for indoor use only
pivot range:	approx. 320° vertical
cooling:	passive, noiseless
light source:	20 W High-Power LED
recommended projection distance in normal room light:	3 m
recommended projection distance in darkness:	8 m
average lifetime of the LED:	35,000 operating hours
colour temperature:	6,500 - 8,000° Kelvin
luminous flux of the LED:	1,700 Lumen
gobo size / image size:	Ø 50 mm / Ø 40 mm
voltage:	100 - 240 V AC / 50 - 60 Hz
active power (power consumption):	27 W
apparent power:	59 VA
efficiency:	0,46 cos. φ
electrical protection:	protection class I
ingress protection rating:	IP 20
photobiological safety:	ICE62471:2006 EN62471:2008: RG-2
item number:	
silver:	20000130
black:	20000120
white:	20000110

## COMPONENTS

Standard series with high power LED, 85 mm standard lens, mounting plate for standing or fixing to walls or ceilings, power cable with plug. The machine is ready to plug in and run. Required accessories: glass gobo with individually designed motif.

We reserve the right to make technical and optical modifications. Our general terms and conditions apply.

## PROJECTION DIAMETER WITH INCREASING DISTANCE

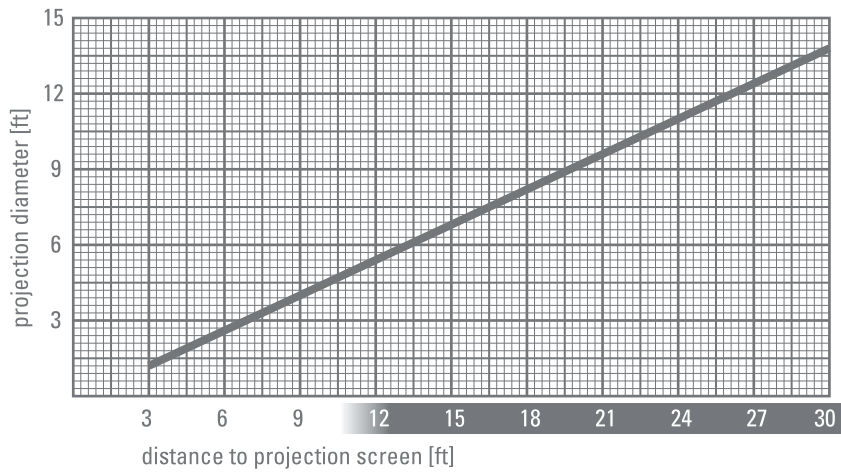

## MEASUREMENTS

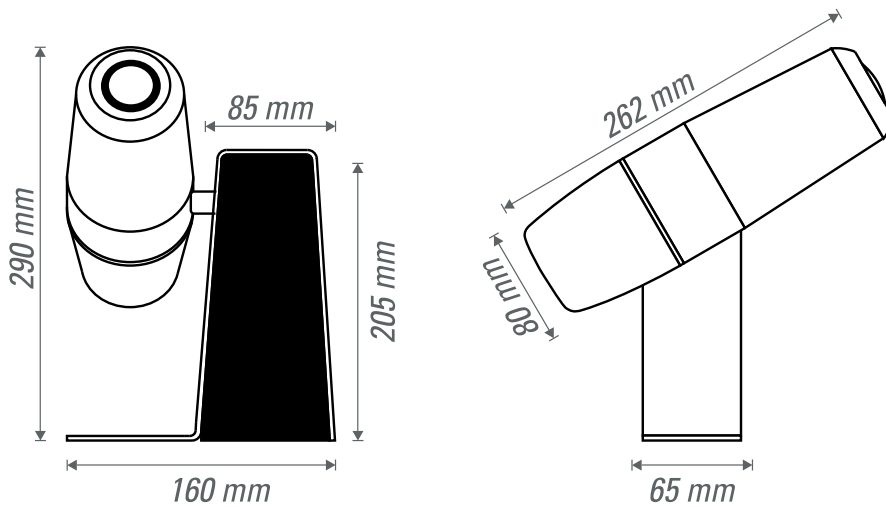

IP 20



derksen®  
lichttechnik

Derksen Lichttechnik GmbH  
Sauerlandstraße 5  
45889 Gelsenkirchen  
Germany

Phone: +49 (0) 209/980 70-0  
Fax: +49 (0) 209/980 70-60

info@derksen.de  
www.derksen.de